

FORMING FACT



BIERSCHBACH EQUIPMENT & SUPPLY

1101 S LYONS AVE
SIOUX FALLS, SD 57101
1-800-843-3707

3030 N PLAZA DRIVE
RAPID CITY, SD 57709
1-800-658-5437

2121 LEECH AVE
SIOUX CITY, IA 51106
1-800-243-3707

4001 MAIN AVE
FARGO, ND 58103
1-800-540-2760

STEEL-PLY CURVED WALL

2' WIDE PANELS WILL READILY FORM CURVED WALLS DOWN TO A 15' RADIUS OR 30' DIAMETER. STANDARD FILLERS CAN BE USED TO FORM SMALLER RADIUS WALLS.

THE OUTSIDE FORMS OF A CURVE OR ROUND TANK REQUIRE 1", 1½" OR 2" FILLERS AT PREDETERMINED JOINT INTERVALS TO KEEP INSIDE AND OUTSIDE PANEL TIE JOINTS OPPOSITE EACH OTHER. THIS IS DUE TO THE LARGER CIRCUMFERENCE COVERED BY THE OUTSIDE FORMS.

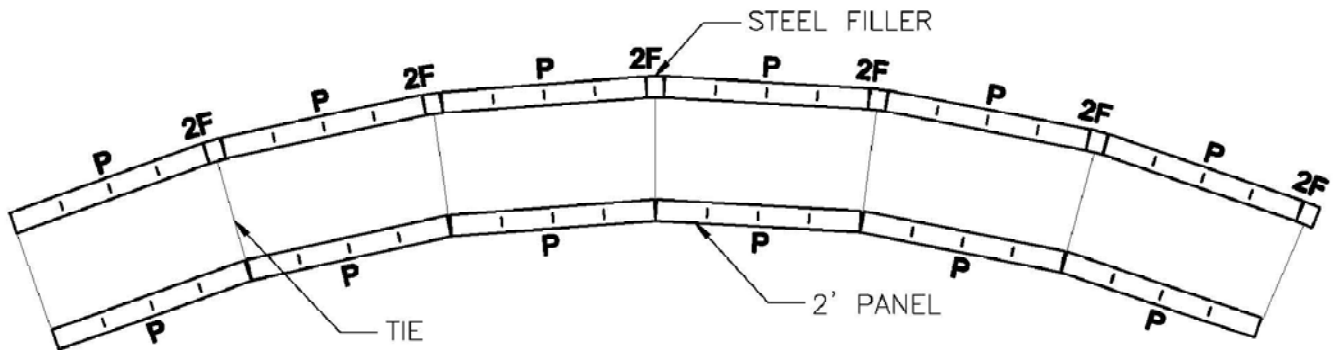

CALL YOUR LOCAL BIERSCHBACH EQUIPMENT FOR A DETAILED FORM LAYOUT OF YOUR PROJECT.